



HOME-ESS-LV-5.3K-S

Quick Installation Guide

Version 02



Android APP



iOS APP



1. Installation Precautions

Flow chart of installation steps:

Please follow the equipment installation steps process to ensure the equipment can be successfully installed.

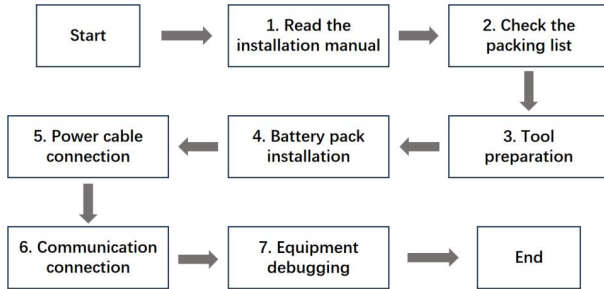

Please ensure that the installer meets the following requirements:

This system should only be installed by personnel with training and adequate knowledge of electrical power systems.

Please ensure that the installation location meets the following conditions:

- The installation and operation environment need to comply with local laws and regulations and relevant international national and regional standards for lithium battery products.
- Install in a dry, well-ventilated environment and secure the equipment on a sturdy and horizontal support surface.
- Avoid water accumulation in the installation location and keep away from water sources such as faucets, sewer pipes, and sprinklers. to avoid water infiltration.
- The environment around the installation location needs to be clean. There is no infrared radiation, heat source, conductive dust, organic solvents and corrosive gases, etc.
- When the equipment is running, the temperature of the under-frame and heat sink will be relatively high, please do not install it in a place where it is easy to be touched.
- When the equipment is running, do not block the ventilation openings or cooling system to prevent high-temperature fires.
- Please choose a sheltered installation site or build an awning to avoid direct sunlight or rain.

Schematic diagram of battery interface:

The definition of each interface must be clear during the installation process, otherwise the wrong connection will lead to installation failure or even damage to the equipment.

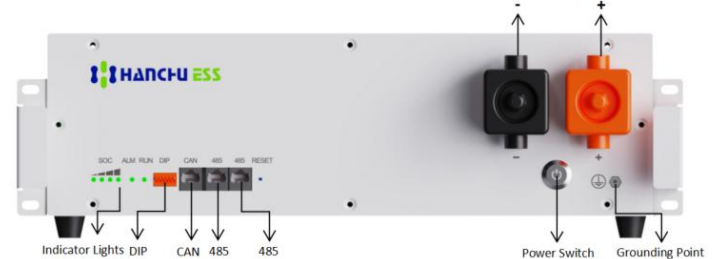

2. Check the packing list

Please refer to the packing items shown below, please check the packing list carefully, if any items are missing, please contact your dealer directly.



Battery



Power cable 1
Black/180mm



Power cable 2
Red/180mm



Power cable 3
Black/1000mm



Power cable 4
Red/1000mm



RS485 communication
line/180mm



CAN communication
line/1000mm



Quick Installation Guide



Ground screw terminal
M6x10/OT6-6/SC-35-8 *2

NOTE : The matching power cable is 3AWG, and the carrying capacity is 120A. Please do not work under the condition of exceeding this current.

3.Tool preparation

Step 1: Protective equipment products must be worn and maintained during the installation process.



Safety gloves



Safety glasses



Safety shoes

Step 2: Installation Tools: tools needed in the process of installing equipment, are more effective to improve installation efficiency.



Phillips screwdriver

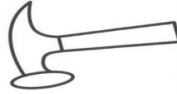

Hammer



Torque screwdriver



Ruler



Electric transfer



Marker pen

4. Battery pack installation

Before you start connecting cables, make sure that the inverter and battery are entirely switched off!

Ensure no water source above or near the battery, including downspouts, sprinklers, or faucets.

The area of the grounding cable shall be prepared at least 6mm^2 , using a ground screw and terminal to connect the ground cable which can ground the battery. The bolt locking torque is 6NM.

Installation method 1:

Cabinet installation (Not included in the product).

- 1) Put the battery into the cabinet at the installation position.
- 2) Secure the battery unit to the cabinet with a nut through the mounting holes.
- 3) Clearance is required around the battery.



Installation method 2:

Put the battery on suitable ground where is dry and well-ventilated is the quicker and more convenient method.

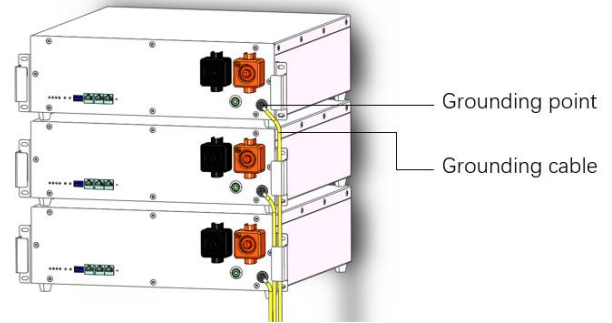

5. Power and communication cable connection

Step 1: Power connections between two batteries

Use power cable 1 to connect the negative pole (P- terminal) of battery A to the negative pole (P- terminal) of battery B, and use power cable 2 to connect the positive pole (P+ terminal) of battery A to the positive pole (P+ terminal) of battery B.

Step 2: Power connections of more than two batteries

Analogy deviation, more than two battery connections, connect the negative poles (P- terminal) between the batteries and connect the positive poles (P+ terminal) between the batteries.

Step 3: Connect the battery to the inverter power supply

After the battery is connected according to Steps 1-2, connect the negative pole (P- terminal) of the battery A and the BAT - terminal of the inverter with the power cable 3; connect the positive pole (P+ terminal) of the battery A and the BAT + terminal of the inverter with the power cable 4.

Step 4: Connect the CAN communication line

Use the CAN communication cable to connect the inverter to the battery's CAN port.

Step 5: Connecting the RS485 communication line between two batteries

Use the RS485 communication line to connect the batteries in sequence through the RS485 port.

Step 6: Connecting the RS485 communication line to more than two batteries

Use the RS485 communication line to connect the adjacent batteries in sequence through the RS485 port.

NOTE :

1. When the inverter is electrically connected, the inverter and batteries need to be powered off.
2. It is forbidden to mix batteries of different brands, specifications and batches, otherwise, it will cause a system failure.
3. The connection between the inverter and the battery must be connected to the CAN communication port of the battery, otherwise communication cannot be performed; similarly, the connection between the batteries must be connected to the RS485 port.

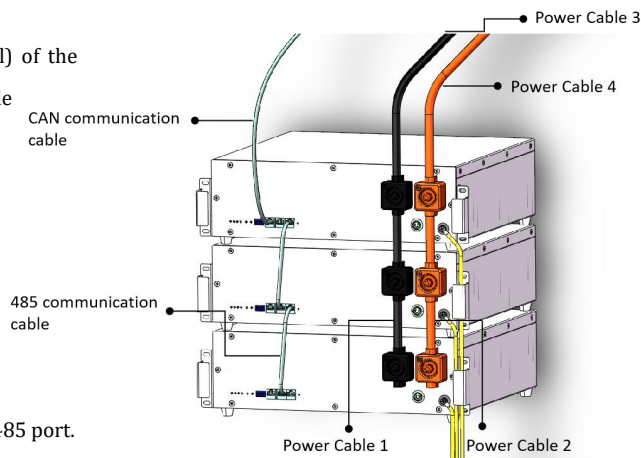















6. Equipment debugging

Step 1: Primary dial setting: DIP address is (1:ON, 2-4:OFF), the battery factory default settings are the master mode and don't need to be changed.

Step2: Subordinate DIP setting: Dip address is #1-#4 , #5 need to be dipped OFF.

NOTE: The battery directly connected to the inverter is the primary and the rest are subordinates.

The DIP Address of primary and subordinate units 1 to 15 are set according to the table below:

Subordinate DIP Address																			
Sub unit	DIP ON	DIP OFF	DIP Address	Sub unit	DIP ON	DIP OFF	DIP Address	Sub unit	DIP ON	DIP OFF	DIP Address	Sub unit	DIP ON	DIP OFF	DIP Address	Sub unit	DIP ON	DIP OFF	DIP Address
1	2	1,3,4,5,6		4	1,3	2,4,5,6		7	4	1,2,3,5,6		10	1,2,4	3,5,6		13	2,3,4	1,5,6	
2	1,2	3,4,5,6		5	2,3	1,4,5,6		8	1,4	2,3,5,6		11	3,4	1,2,5,6		14	1,2,3,4	5,6	
3	3	1,2,4,5,6		6	1,2,3	4,5,6		9	2,4	1,3,5,6		12	1,3,4	2,5,6		15	/	1,2,3,4,5,6	

NOTE: The address allocation principle is binary. The battery address setting in the same system cannot be repeated.

Step 3: Equipment power on

After confirming that the cables are connected in the correct order and the connections are tight, the system is powered on and switched on in the following order:

- 1) Press the battery power switch in turn (first the master, then the slave 01~15) to start the battery.
- 2) Observe whether the status of the indicator light on the battery panel is normal ('RUN' green light flash, 'ALM' light off). Indicator light is normal can continue in order to power on. If the indicator light is faulty, you need to remove the fault and then power on.
- 3) Close the circuit breaker on the battery and the circuit breaker between the battery and the inverter.
- 4) The power-up process of the inverter is carried out according to the manual process of the inverter.

NOTE: The shutdown procedure is opposite to the startup process, first shut down the battery pack; then disconnect the circuit breaker of the inverter.

When the system starts, ensure the boot sequence of each piece of equipment, otherwise it may cause pre-charging and trigger the circuit breaker protection fault.





Step 4: Inverter Protocol Selection: The battery default factory CAN communication is Hanchu ESS protocol and RS485 communication is SRNE protocol.





Protocol selection:

- 1) Check which protocols are supported by the inverter.
- 2) If the inverter supports the battery factory default protocol, select the corresponding protocol on the inverter directly.
- 3) If the inverter supports protocols other than the battery factory default protocol, select the same protocol on the battery and the inverter.

Battery protocol selection: Select the protocol in the #5 position of the primary DIP Address.

Inverter brands using the **CAN** or **RS485** communication protocol need to set the Primary DIP Address according to the following table:

CAN communication			
Primary unit	DIP ON	DIP OFF	Inverter brands
	1	1,2,3,4,5,6	VICTRON、SMA
	1,6	2,3,4,5	HanchuESS、Luxpower
	1,5	2,3,4,6	Aiswei
	1,5,6	2,3,4	Deye、Pylon

RS485 communication			
Primary unit	DIP ON	DIP OFF	Inverter brands
	1	2,3,4,5,6	Voltronic
	1,6	2,3,4,5	SRNE
	1,5	2,3,4,6	/
	1,5,6	2,3,4	SMK

Contact

Hotline:+86-51088876668/+86-51088865288

Service Email: service@hanchuess.com

Web: www.hanchuess.com